

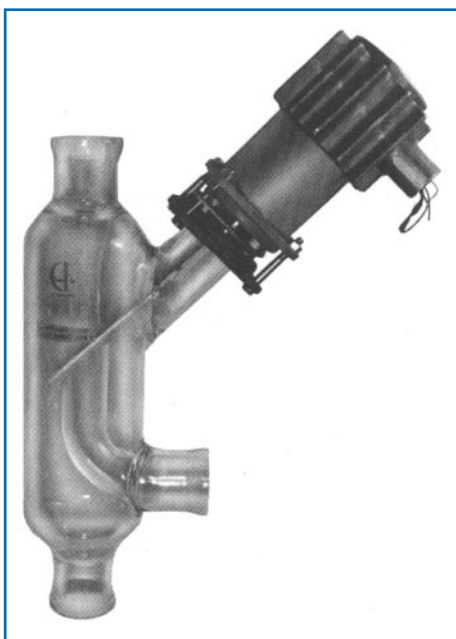

CHEM FLOWTRONICS

Glass — In-Line Design Reflux Splitters



PERFORMANCE

The splitter is electrically operated by a timer and a solenoid which provide accurate control. Reflux splitters facilitate measurement and control at a single station, streamlining your system. The precision timer has an adjustable ratio of 1:1 and 1:120 seconds. This timer is available in general purpose or Class 1, Group D enclosure. (See Bulletin RS-2T)

FLOW RATES

Size	COLUMN DESIGN		Size	IN-LINE DESIGN	
	Min.	Max.		Min.	Max.
3" - 9	0.14 GPM	at 0" HEAD	1" - 9	0.14 GPM	at 0" HEAD
	1.5 GPM	at 4" HEAD		2.0 GPM	at 21" HEAD
3" - 16	0.6 GPM	at 0" HEAD	1" - 16	0.6 GPM	at 0" HEAD
	4.2 GPM	at 4" HEAD		7.7 GPM	at 21" HEAD
4" - 25	1.0 GPM	at 0" HEAD	1½" - 25	1.0 GPM	at 0" HEAD
	10.4 GPM	at 5" HEAD		19.0 GPM	at 21" HEAD
6" - 28	1.5 GPM	at 0" HEAD	2" - 28	1.5 GPM	at 0" HEAD
	15.0 GPM	at 5" HEAD		23.0 GPM	at 21" HEAD

Larger sizes available on special order.

SPECIFICATIONS

PRESSURE AND TEMPERATURE RATINGS:

Maximum Pressure	
In-line Design	50 psi
Column Design	3" — 40 psi
	4" — 35 psi
	6" — 20 psi
	9" — 15 psi
	12" — 11 psi

Maximum Temperature	450° F
Thermal Shock	200° F

ELECTRICAL CHARACTERISTICS:

Current Input	110 Volts AC
Rectifier Rating	P.I.V. 200 (6 AMPS)
Solenoid Coil Rating D.C.	
DCR	48 V. D.C.
OHMS	59.4 OHMS
AMPS	1.9 AMPS
TIMER (Rated 10 AMPS)	
Single Phase	60 Cycle 110 V. A.C.

COMPLETE CORROSION RESISTANCE

Borosilicate glass and TFE construction insures corrosion resistance to all liquids except hydrofluoric acid and hot concentrated caustics.

VISIBILITY

The glass construction of the reflux splitter insures the ultimate in process control by giving the operator full visibility at all times.

Glass — In-Line Design Reflux Splitters

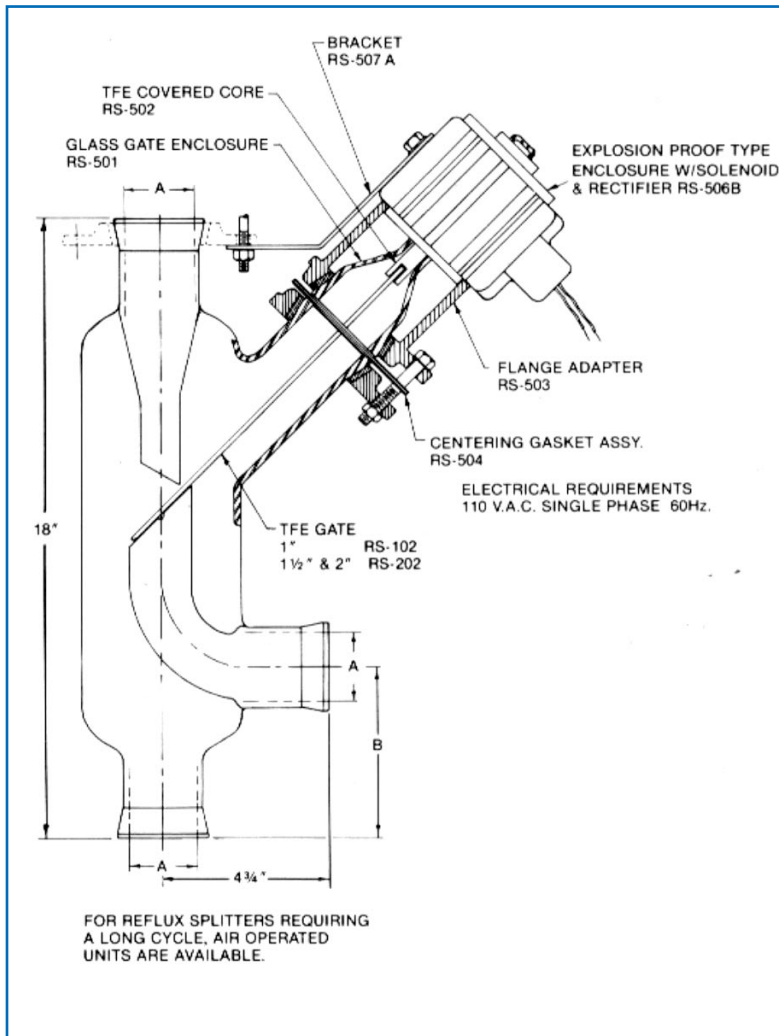

IN-LINE DESIGN

The design shown on the right has the same simple construction as the column design — two moving parts, the TFE gate and TFE enclosed core.

Size	A	B	Cat. No.
1" - 9	1"	5 5/16"	SP-25/9-GL
1" - 16	1"	5 5/16"	SP-25/16-GL
1 1/2" - 25	1 1/2"	5"	SP-40/25-GL
2" - 28	2"	5"	SP-50/28-GL

NOTE: All units are supplied without flanges for line connections.

NOTE: Explosion proof solenoid shown on both drawings. General purpose solenoid available.

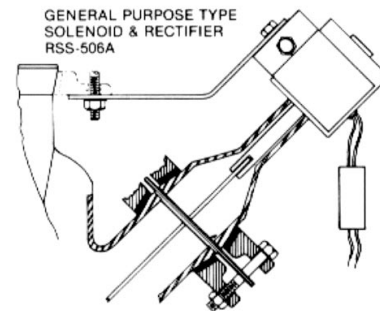

Features:

- Simplified Design
- Only One Moving Part
- Accurately Calibrated Flow Rates
- Dependable Fail-Safe Design
- Borosilicate Glass and TFE
- Construction for Optimum Corrosion Resistance and Visibility
- Explosion-Proof or General Purpose Electrical Construction



CHEM FLOWTRONICS

Chem Flow Corporation
P.O. Box 4635, Wayne NJ 07474-4635
Tel: 800-486-3356 · 973-785-0001 · Fax: 973-785-8051
Email: info@chem-flowtronics.com
Web: www.chem-flowtronics.com